

# SOME OF THOSE WE HAVE BEEN PRIVILEGED TO SERVE :

Barr & Wray-  
Coca Cola Alt-  
antic / Midi / Swepe,  
HP Bulmer, Kraft, Gen-  
eral Foods / Jacobs / Suchard  
Nestle UK, Rowntree Macintosh, St  
Ivel British Sugar, Tate & Lyle citric, Tetley  
Carlsberg, William Grants & Son, Cussons,  
Glaxo Foundation, I.C.I. Pharmaceuticals, McBrides,  
Pfizer, Proctor and Gamble, Roche, Andrew Jergens, Bayer, Aventis-  
Zeneca Pharmaceuticals, -- Myers, Burroughs Wellcome, Biopure, Bristol-  
-Gillette Co., Johnson & Johnson, Merrell Dow, NDM Corp.,  
Ohio Medical Carbide, Pharmacia Biotech, Unilever Research  
Pharmaceuticals (USA), The Upjohn Co., Univesal -  
Amalgamated Sugar, Proctor & Gamble (USA),  
Coors Brewing, Admiral Beverage, Warner Lambert -  
Foods, Hershey & Julio Gallo, Bake Rite,  
Kellogg Co., M & M Mars, Malt O Meal, Nestle Foods,  
Paterson Candy International, Quaker Oats,  
Ralston Purina, Western Sugar,  
Tropicana,

Dis-assembly and service instructions for other damper types are on the rear cover of each product leaflet

## 5 MINUTE DOWN TIME PULSE DAMPERS

### \* MOUNTING BLOCK / Piping Base PRODUCTS

**WARNING** Pulse Dampers may be energy storing, Proceed with EXTREME CARE

### \* THE PIPEHUGGER Bolted configuration

The bolted damper capsule body also speeds & simplifies disassembly compared to the tamperproof segmental lock ring standard

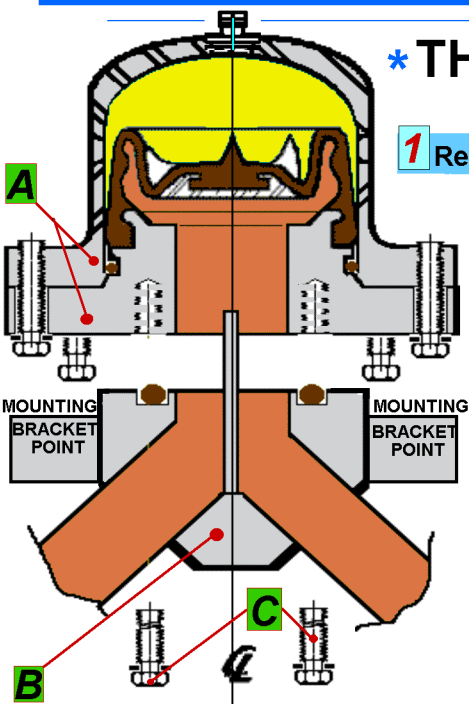

**1** Release the DAMPER CAPSULE **A** from the MOUNTING BLOCK **B** piping base.  
by removing bolts **C** (NB. Not stressed for pipe loadings)  
NEVER RESTRAIN THE DAMPER CAPSULE

**2** Open Cushion Pre-Fill Valve 9019c, pt. **D** (see schematic)  
By removing the yellow sealing cap, and turning the 3/4" AF swivel nut.  
When all pre-fill pressure is released, unscrew the valve body and set care-  
fully aside

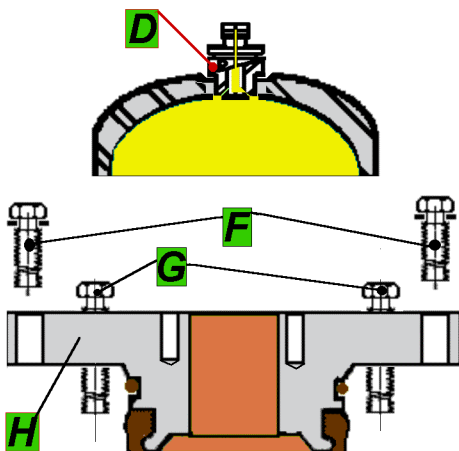

**3** Without scratching the sealing for Valve **D**  
Stand capsule on dome end **E**  
Remove all of 4, 8, or 12 bolts **F**

**4** Using Jacking bolts **G**  
Lift base plate **H** out of dome **E**

**SCHEMATIC of D**  
Pre-Fill Valve 9019c/304ss is used on all civil and military aircraft. It is totally reliable, and must not be replaced with other items.  
9019c is opened & closed with 3/4" wrench. No special tools required.

Sealing Cap  
Swivel Nut  
Body  
"O" Seal  
Cone Seat  
Rising Stem

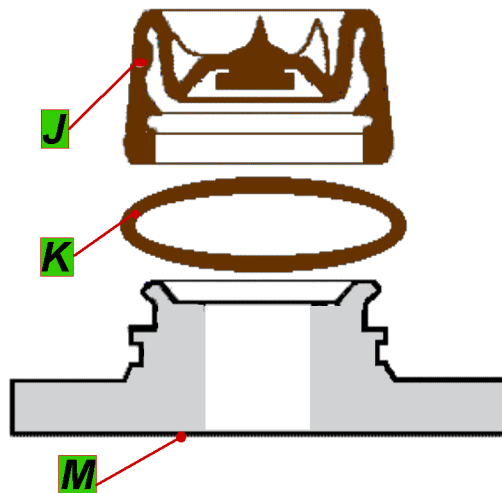

**5** Place base plate on a smooth clean surface so as not to damage sealing surface **M** remove bladder **J** and "O" seal, **K** place them in a plastic bag, seal the bag, & return it to factory immediately ■